

ANSI FLEX SEAL LINE

The Versatile Standardized Solution for ANSI Pumps

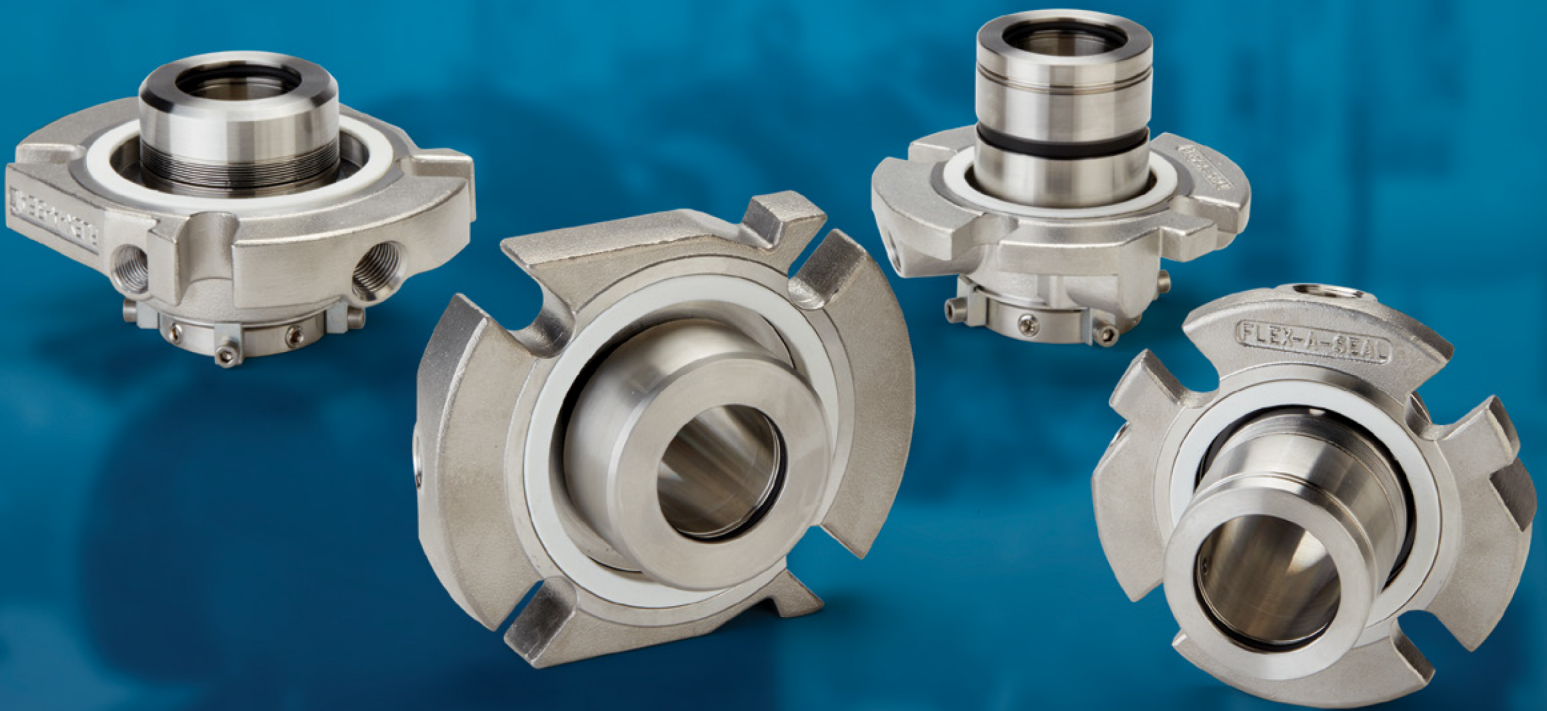

Conventional pump stuffing boxes were originally designed to accommodate packing materials. Over the years mechanical seals edged out packing as a preferred sealing method; however stuffing boxes essentially remained the same. This situation posed complications for the effective operation of mechanical seals including installation issues, potential damage from abrasive product, and poor dispersion of seal-generated heat.

The ANSI Standard ASME B73.1 Specifications for Horizontal End Suction Centrifugal Pumps for Chemical Process includes requirements to improve the reliability and safety of the B73.1 pump design. One major specification focuses on cylindrical (big bore) and self-venting (tapered bore) seal chambers to address issues which plague standard bore seal chambers. The enlarged chambers provide additional radial clearance for mechanical seal operation and for increased liquid circulation around the seal, enabling the seal to run cooler and longer.

The ANSI Flex Difference

- Big Bore faces are designed with larger ODs for additional radial clearance and seal cooling
- Both standard and big bore glands supplied with 3 connections to accommodate any piping plan
- Set clip redesign for even easier seal installation

ANSI FLEX ARB3 (STANDARD) & ABRB3 (BIG BORE)

Materials of Construction

Rotating Seal Face: Carbon, Tungsten carbide, Sintered silicon carbide

Stationary Seal Face: Sintered silicon carbide

Bellows: Hastelloy® C276

Metallurgy: 316 SS

Elastomers: Viton®, Ethylene propylene, Aflas®, Buna, Neoprene, Perfluorelastomer

Gland Gasket: Glass-filled Teflon™

Throttle Bushing: Glass-filled Teflon™



« ARB3

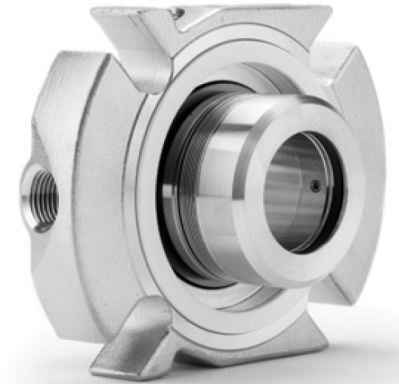

ABRB3 »

Operating Parameters

Temperature: 400° F (200°C)

Pressure: 300 PSI (20 Bar)

Speed: 4500 FPM

ANSI FLEX ASMS3 (STANDARD) & ABSMS3 (BIG BORE)

Materials of Construction

Rotating Seal Face: Sintered silicon carbide

Stationary Seal Face: Carbon, Sintered silicon carbide

Springs: Hastelloy® C276

Metallurgy: 316 SS

Elastomers: Viton®, Ethylene propylene, Aflas®, Buna, Neoprene, Perfluorelastomer

Gland Gasket: Glass-filled Teflon™

Throttle Bushing: Glass-filled Teflon™



« ASMS3

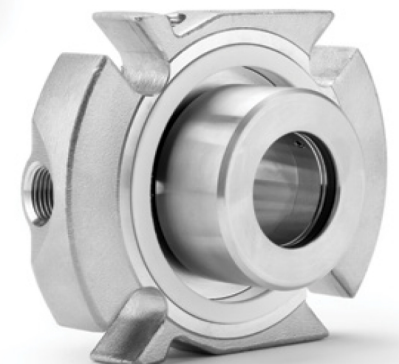

ABSMS3 »

Operating Parameters

Temperature: 400° F (200°C)

Pressure: 300 PSI (20 Bar)

Speed: 6000 FPM

* Maximum temperature/speed/pressure/runout indicates operating extremes independently and does not imply the seal will function at these extremes at the same time.

ANSI FLEX LINE FEATURES

- Simple cartridge seal installation
- Sleeve is isolated from process fluid
- 3/8 NPT flush connection allows for cooling and venting of seal.
- 1/4 NPT vent and drain connections provide differential sizing to minimize the potential of improper piping
- Non-sparking throttle bushing is positively retained to avoid pressure blow out, minimizing leakage in the event of seal failure.
- ANSI Flex glands include flush, vent, and drain connections and a close-clearance, non-sparking throttle bushing to direct any leakage to the drain connection.
- Angled gland connections allow for easier pipe fitting.
- Setting clips provide positive axial and radial setting of the ANSI Flex cartridge seal to insure proper seal installation. The ANSI Flex clips are easy to access for simple removal.
- Only one Allen wrench required to tighten screws and remove the setting clips.

INDIVIDUAL STYLE FEATURES

ASMS3/ABSMS3

- Stationary springs and drive pin mechanism isolated from process fluids to minimize corrosion, clogging, and stress-related failures
- Unique, metal-shrouded rotary seal ring for maximum face protection and uniform 360° transfer of torque to the rotating face during start up.
- Dynamic elastomer moves on non-metallic, smooth surface eliminating fretting
- Stationary design for optimal face alignment

ARB3/ABRB3

- Rotating design uses centrifugal force for self-cleaning
- Uniform 360° transfer of torque to the rotating face
- Welded metal bellows replace the dynamic elastomer which can hang up the seal faces
- No springs to clog or break
- No fretting
- Only two (2) static elastomers – eliminate seal failures caused by dynamic O-ring “hang up” and offers cost savings when upgrading to Perfluorelastomers.

INDIVIDUAL BIG BORE FEATURES



ABSMS3

Monolithic rotating seal ring made from a solid, homogenous material and is easily field-repairable.



ABRB3

Floating stationary seat design adjusts for misalignment and is cushioned from vibration, both of which improve face tracking.

Dimensional Chart – ASMS3 & ARB3 Standard Bore Seals

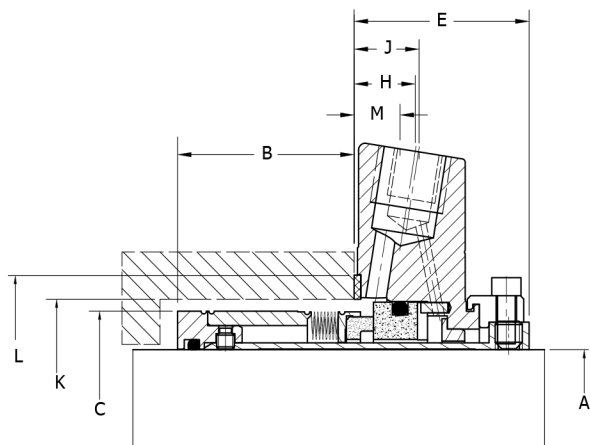

A	B	C	D	E	F
SHAFT DIAMETER	INBOARD LENGTH	INBOARD O.D. ASMS3 & ARB3	GLAND O.D.	OUTBOARD LENGTH	SLOT WIDTH
1.375	1.600	1.950	4.250	1.625	0.525
1.750	1.630	2.450	5.500	1.615	0.625
1.875	1.630	2.575	5.500	1.615	0.563
2.125	1.585	2.825	6.000	1.805	0.688
2.500	1.650	3.320	6.500	1.805	0.750
2.625	1.650	3.560	6.500	1.805	0.688

A	G	H	J	K	L	M
SHAFT DIAMETER	BOLT CIRCLE	FLUSH LOCATION	VENT/RAIN LOCATION	GASKET I.D.	GASKET O.D.	GLAND LENGTH AT STUDS
1.375	3.250	0.605	0.675	2.165	2.605	0.425
1.750	3.800	0.562	0.562	2.665	3.105	0.625
1.875	3.875	0.562	0.670	2.790	3.230	0.625
2.125	4.375	0.562	0.650	3.165	3.605	0.625
2.500	4.700	0.562	0.650	3.500	3.855	0.625
2.625	4.875	0.562	0.650	3.625	4.070	0.625

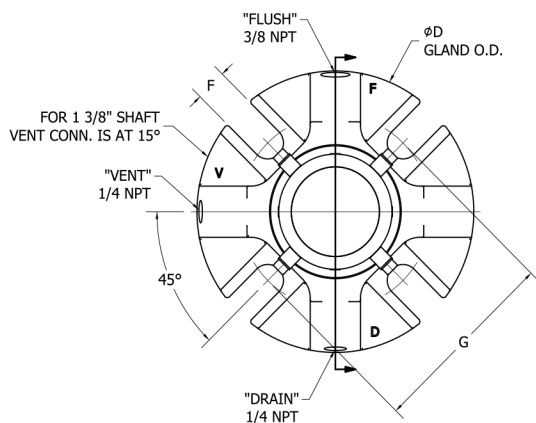

Dimensional Chart – ABSMS3 & ABRB3 Big Bore Seals

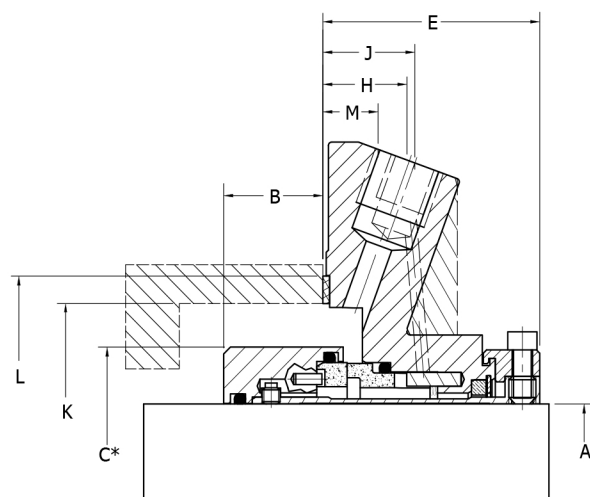

A	B	C		D	E	F
		INBOARD O.D. ASMS3	ARB3			
SHAFT DIAMETER	INBOARD LENGTH	ASMS3	ARB3	GLAND O.D.	OUTBOARD LENGTH	SLOT WIDTH
1.375	0.847	2.407	2.187	5.250	2.000	0.500
1.750	0.915	2.782	2.562	6.500	2.000	0.625
1.875	0.945	2.907	2.687	5.875	1.970	0.625
2.125	0.955	3.157	2.937	7.250	1.970	0.750
2.500	1.093	3.687	3.437	8.000	1.970	0.750
2.625	1.030	3.813	3.625	7.000	2.000	0.625

A	G	H	J	K	L	M
SHAFT DIAMETER	BOLT CIRCLE	FLUSH LOCATION	VENT/RAIN LOCATION	GASKET I.D.	GASKET O.D.	GLAND LENGTH AT STUDS
1.375	4.000	0.605	0.750	2.875	3.375	0.815
1.750	4.750	0.800	0.812	3.570	4.070	0.775
1.875	4.800	0.800	0.812	3.570	4.070	0.712
2.125	5.750	0.800	0.812	3.875	4.610	0.712
2.500	6.375	0.800	0.812	4.700	5.325	0.712
2.625	6.000	0.800	0.812	4.625	5.125	0.775



www.flexaseal.com
sales@flexaseal.com

USA

1 Jackson Street
P.O. Box 184
Essex Junction, VT 05453

TEL 1-800-426-3594
1-802-878-8307
FAX 1-802-878-2479

BRAZIL

Rua Javaes, 441/443
Bom Retiro, Sao Paulo
Brazil CEP 01130-010

TEL 55-11-3736-7373
55-11-3736-7371
FAX 55-11-3736-7355

DISTRIBUTED BY